

Corporate Image's many years of experience developing eco-friendly presentation solutions was a perfect fit for The HON Company's need to tell their own sustainability story in custom packaging.



The HON Company

Custom: Corrugated Sales Tote
3c PMS
Matte Lamination



“At The HON Company, we needed to tell our sustainability story and worked with Corporate Image to produce a unique, environmentally friendly package. From knowing which eco-friendly materials to use, through package design, Corporate Image showed they really understood our needs and the importance of matching our message with the right presentation solution.”

Chad Johnson, The HON Company

Sales Boxes & Corrugated Packaging

Sales Boxes

Our Sales Boxes serve a wide variety of uses. Often used to organize printed pieces as a kit, they offer more capacity than Pocket Folders.

Corrugated Packaging

Our Corrugated Packaging brings incredible durability to your design, without compromising your high-end graphics. Every Corrugated Package we produce is custom, so we're confident we can meet your needs.



Silver Oaks Communications
Custom: Corrugated Packaging



Wellmark Blue Cross and Blue Shield

310: Sales Box

Room & Board

Custom: Corrugated Packaging



Sales Boxes & Corrugated Packaging

unique
efficient
sturdy
impressive
functional



Miller Brooks
301: Sales Box

Tuck-Lock Sales Boxes

Another unique presentation solution, Sales Boxes are economical, easy to assemble and can be customized to fit your needs. They are shipped flat, which saves shipping costs and reduces warehouse storage. Simply fold the scores then tuck in the locking tabs. Add a set of Tab Dividers or File Folders to create a complete kit.

Materials

- Eco-friendly FSC certified papers
- 100% recycled paper is available
- 18- or 24-pt. stock, coated or uncoated
- Four-color process soy inks
- Lamination optional (page 22)



Room & Board
Custom: Corrugated Packaging

Thoroughbrand
Custom: Corrugated Packaging

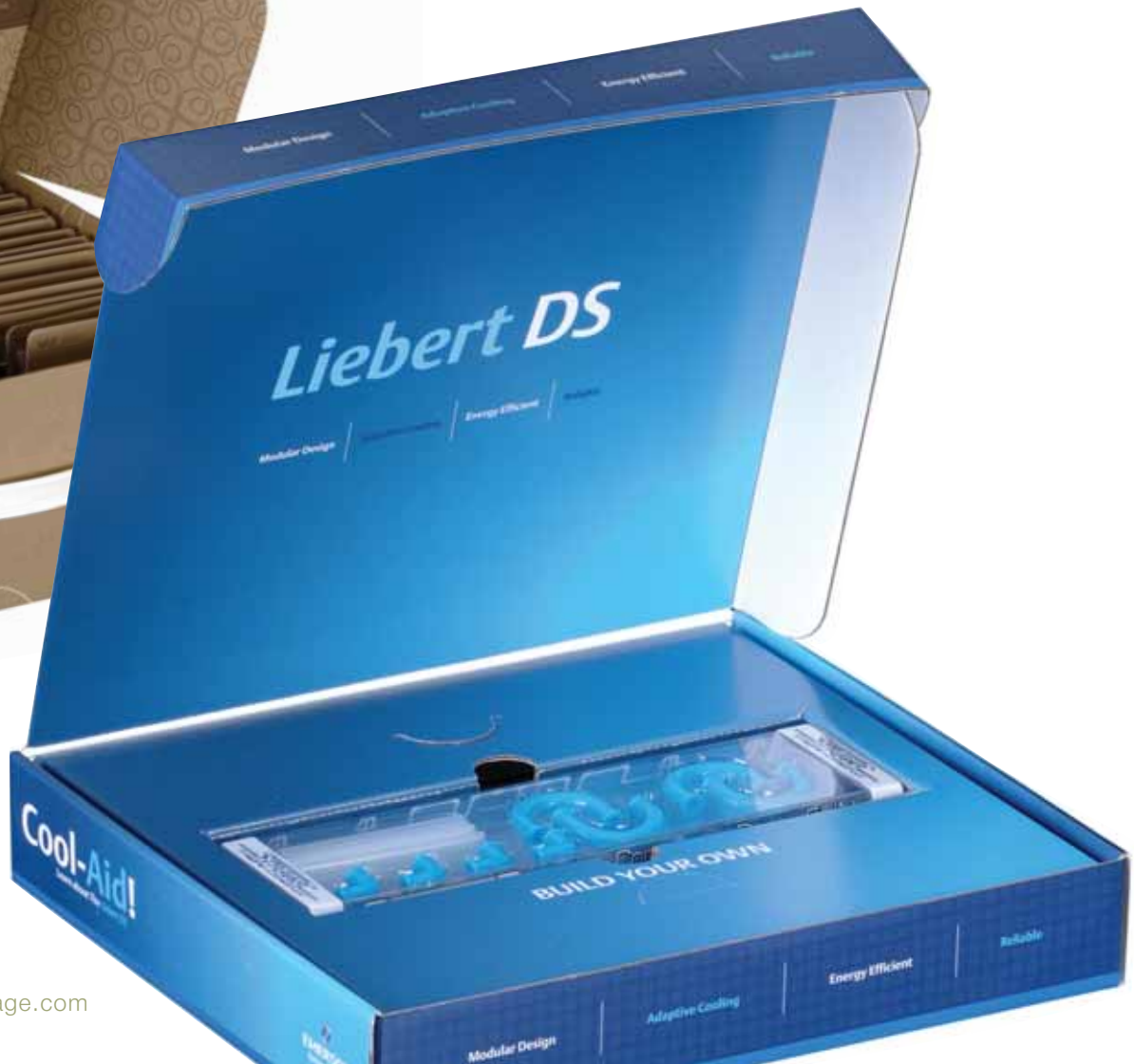



GREEN INNOVATIONS

Sales boxes and corrugated packaging from Corporate Image are a smart, green solution for kits, mailers and totes. They are efficient, economical, easy to assemble and easy to recycle. Our ongoing process of “Review, Refine, Reduce and Redesign” applies to them, too.

Our Tuck-Lock Sales Boxes are offset printed directly on FSC certified 18- or 24-pt. board stock. Printing and design options are not restricted. You can choose to finish the box with aqueous coating or chemically inert film lamination for extra strength.

There’s no glue on our boxes. They ship flat, reducing manufacturing costs and energy, shipping costs and storage space. Just assemble them on demand by folding the scores and inserting the locking tabs. We’ve redesigned our boxes to replace Velcro® closures with creative tuck closures, giving you yet another eco-friendly option.

Durable corrugate packaging is another green solution. Once again, boxes ship flat with the same benefits. On average, corrugate is composed of 30% post-consumer waste and is 100% recyclable. Boxes, mailers and totes can be wrapped in a beautifully printed litho sheet. Or, the corrugated surface can be printed directly and recycled easily.

We have made great progress and will continue our efforts to provide well-designed sustainable products. It is an ongoing process and commitment.

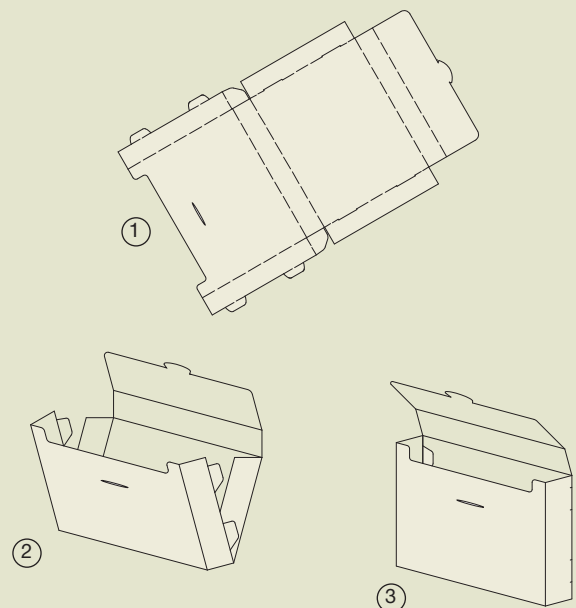

EASY TO ASSEMBLE



AllSteel
Custom: Corrugated Packaging

Corrugated Packaging

This durable solution is lightweight yet incredibly strong. Boxes can be customized in an infinite number of ways. They can be direct printed on smooth brown kraft or bleached white corrugated stock, or a laminated offset printed sheet can be applied to the corrugate, creating a beautiful package.

- Complete design flexibility
- Direct print and offset printed boxes available
-  • Corrugate is recyclable
-  • Four-color process soy inks
-  • Lamination optional (page 22)

Sales Boxes



features	style	description	size
<p>Complete design flexibility.</p> <p>Full color graphics inside and out.</p> <p>Sales Boxes may be laminated to provide protection for your graphics and add to the durability of the sales box.</p> <p>Choice of gloss, semigloss or natural matte lamination. All laminations are available with a linen finish (page 22).</p> <p>Customize your sales box with a handle or custom die-cuts.</p> <p>NEW! All Sales Box locking tabs have been redesigned for more stability.</p> <p>Customizing We offer a wide range of styles and sizes to meet your needs. Ask your sales representative about additional sizes.</p>		<p>18-pt. and 24-pt. Square Flap Center Tuck Closure Sales Boxes</p>	<ul style="list-style-type: none"> • 300: 1/2" deep, 18-pt. • 301: 1" deep, 18-pt. • 302: 1-1/2" deep, 24-pt. • 303: 2" deep, 24-pt.
		<p>18-pt. and 24-pt. Square Flap Side Tuck Closure Sales Boxes</p>	<ul style="list-style-type: none"> • NEW! 304: 1" deep, 18-pt. • NEW! 305: 1-1/2" deep, 24-pt. • NEW! 306: 2" deep, 24-pt.
		<p>18-pt. and 24-pt. Round Flap Center Tuck Closure Sales Boxes</p>	<ul style="list-style-type: none"> • 307: 1/2" deep, 18-pt. • 308: 1" deep, 18-pt. • 309: 1-1/2" deep, 24-pt. • 310: 2" deep, 24-pt.
		<p>NEW! FlexHinge 18-pt. and 24-pt. Round Flap Center Tuck Closure Sales Boxes</p>	<ul style="list-style-type: none"> • NEW! 311: 1" deep, 18-pt. 11-1/4"(w) x 9-5/8"(h) • NEW! 312: 1-1/2" deep, 24-pt. 11-1/4"(w) x 9-7/8"(h) • NEW! 313: 2" deep, 24-pt. 11-1/4"(w) x 10-1/8"(h)

NOTE: Product numbers 300-310 measure 11-1/4"(w) x 9-1/8"(h). Measurements for Sales Boxes are inside dimensions.

Corrugated Packaging



SALES BOXES & CORRUGATED PACKAGING CHECKLIST

CONGRATULATIONS! Your design has been approved!

- Call your sales representative to review your projects' specifications
 - Select box style
- Determine quantity (minimum order of 500)
- Select paper stock
 - Uncoated or Coated
 - 18-pt. or 24-pt. or corrugate
- Decorating options
 - Determine number of colors
 - 1- or 2-sided printing
 - Lamination (optional)
 - NEW!** Natural Matte, Gloss, Semigloss
 - Linen Texture
 - Foil Stamping
 - Debossing or Embossing
- Design details
 - Flap — square, round or custom shape
 - Handle or no handle
- Review companion pieces to complement your box
- Watch for your template to arrive via email

- Create your final production file to fit the template
- Send a disk or upload your files to our FTP site
- Select your proof: a digitally printed proof or a pdf proof for faster turn time. Upon receipt of your approved proof, your production schedule will be set.

CONGRATULATIONS! Your project is complete!

